

Model 3CAV

Recirculatory Air Door Vestibule

- *Three Single Recirculatory Air Doors Designed To Work Together as a System*
- *Proprietary Nozzle Design*
- *Greatly Diminishes Air and Moisture Infiltration*
- *Horizontal, Curvilinear, Recirculatory Air Flow*
- *Powder Coated Steel*
- *Metal Clad Insulation When Required*



TRIPLE CONDITIONED AIR CURTAIN VESTIBULE, FREEZER TO AMBIENT SPECIFICATIONS:

Supply where indicated on plans HCR Model 3CAV Air Vestibule for doorways between Freezers and Coolers or ambient.

Air Door to be powder coated cold-rolled steel. Powder coating meets 500 hour salt spray test.

NEMA 1 Power/control panel complete. Model 3CAV equipment cabinet houses the centrifugal fan and prewired electrical components. Service door(s) are provided, if required, to allow access to all internal components. Motor is controlled by VFD

(Variable Frequency Drive). Single point electrical power connection in most cases.

Model 3CAV to have six side plenums: three with discharge nozzle, the other three with an intake.

Discharge nozzle is easily adjustable to maximize air block. Air volume adjustment mechanisms are easily accessible without removing any covers or secondary openings.

Unit can be mounted on either side of wall. Depending on temperature differential insulation cladding may be required.

Air Door assembly is structurally self-supporting. All hardware has protective coating against corrosion.

Air Door power to be 208, 240, or 480 volt AC, 60 Hertz, 3 phase. Visible signal light to show when motor is not running. Complete door assembly to be ready for connection to power. (Architect to designate responsibility for field wiring.)

FREEZER DOOR SPECIFICATIONS:

Supply where indicated on plans HCR Model 3CAV for freezer doorways with temperature differentials greater than 40 degrees Fahrenheit. Provide insulation cladding as may be required for the specific application.

Air Doors forming Model 3CAV can be mounted either on the warm side or the cold side of the wall or split mounted.

Electric resistive heat or waste heat reclaim as required.

OPTIONS: (SPECIFY which options are desired)

1. Metal cladding can be stainless steel or cold-rolled steel powder coated to custom color.
2. 'Clean outs' can be added where needed.
3. Complete NEMA 3, 4, 4x, 4x stainless, or 12 requirements.
4. Hot Gas Coil instead of resistive heat.
5. Custom standoff panels with trim to interconnect to night doors or existing doors.
6. HCR Air Door to be used in conjunction with existing or new door to form a Hybrid solution. These doors can include all types of insulated roll up doors, double curtain roll up doors, hard insulated automatic doors that slide either horizontally or vertically, or insulated sliding mattress type doors.

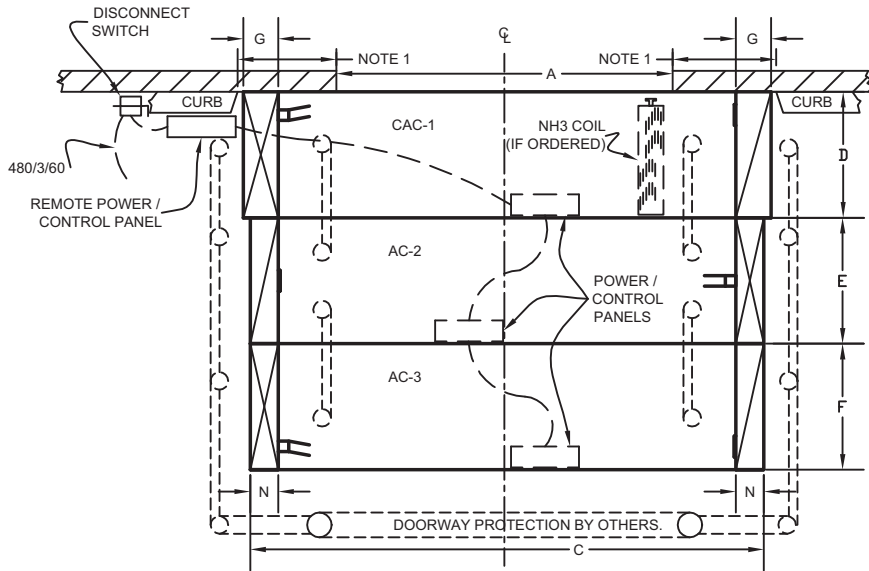

PLAN VIEW

NOTES:

1. 30" MINIMUM CURB TO DOORWAY CLEARANCE REQUIRED.
2. DISCONNECT SWITCH NOT PROVIDED.

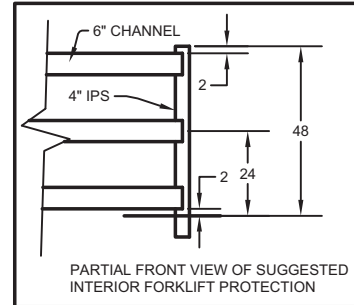

**BOLLARD SECTION
(SUGGESTED)**

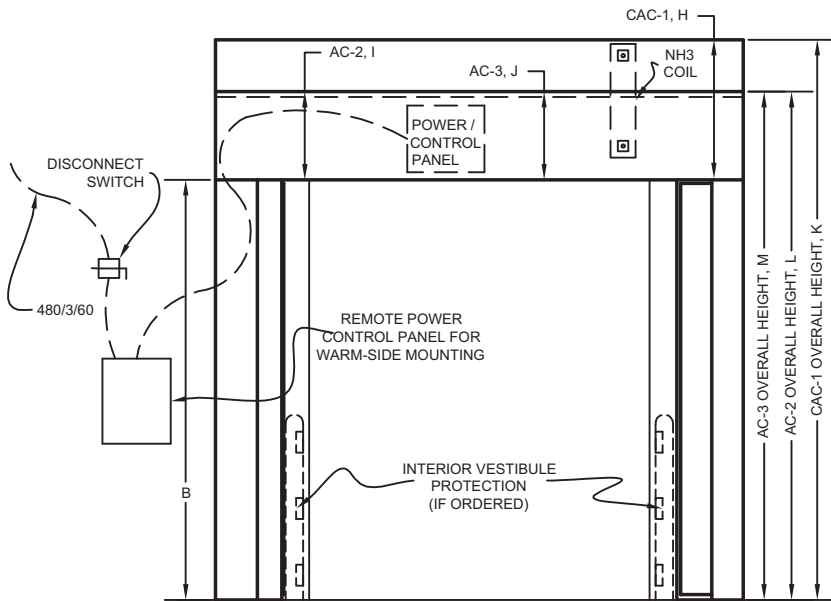

ELEVATION

Warranty:

Provide warranty for a minimum period of one (1) year from the date of equipment start up by contractor or sub-contractor, according to the manufacturers' standard terms and conditions.

INSTALLATION POINTS:

1. Install air curtains, hardware, and electrical components in strict accordance with Architect's drawings and specifications and the door manufacturer's written instructions.
2. Complete installation, operating, and maintenance instructions shall be supplied for each door by manufacturer.
3. Manufacturer shall furnish all hardware necessary to install Air Doors, to wood or steel bucks, including trim, anchor bolts and floor clips.
4. Install plenums plumb and square, in correct locations indicated on drawings and with a maximum diagonal distortion of 1/4" over height of doorway. Ensure top equipment cabinet is securely and rigidly anchored to adjacent construction.

JAMISON

Jamison Door Company • P.O. Box 70 • Hagerstown, MD 21741-0070
 Call Toll Free • 1-800-532-3667 or 301-733-3100
 FAX: 240-329-5155
 INTERNET: <http://www.jamisondoor.com>
 E-MAIL: contact@jamisondoor.com