

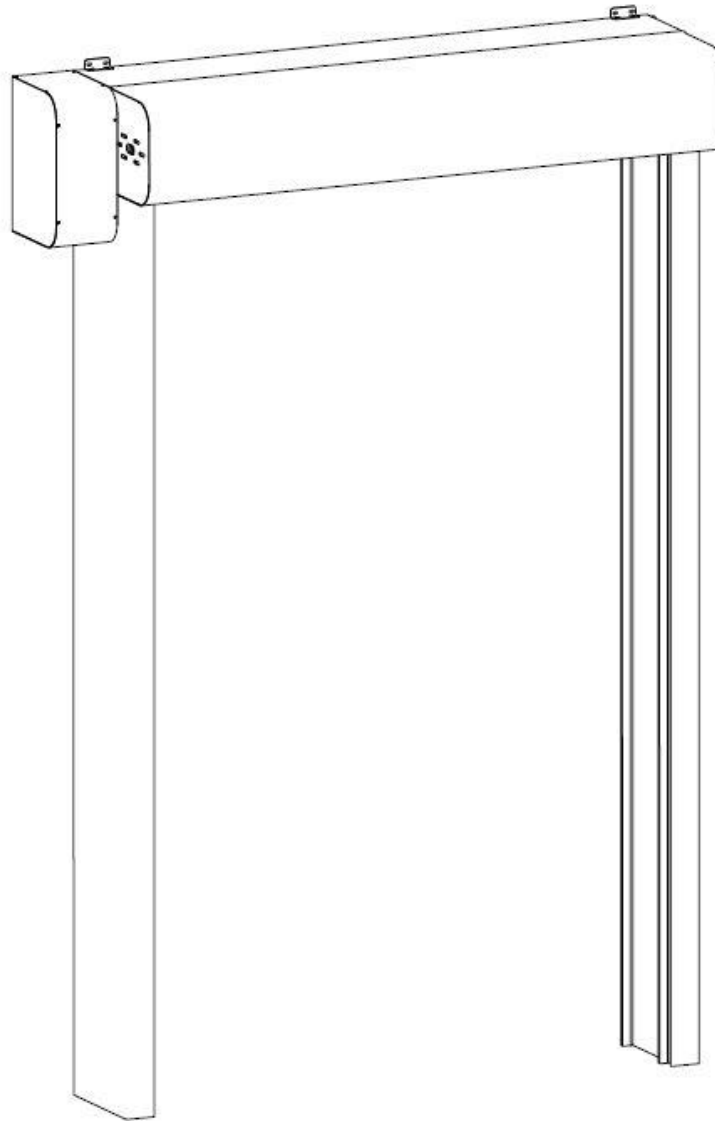

## Frigo 2 Installation Instructions



**JAMISON DOOR COMPANY**  
P.O. BOX 70  
HAGERSTOWN, MARYLAND 21741  
1-800-532-3667 301-733-3100  
INTERNET: <http://www.jamisondoor.com>  
E-MAIL: [contact@jamisondoor.com](mailto:contact@jamisondoor.com)

## INSTALLATION INSTRUCTIONS INDEX

1. INSTALLATION OVERVIEW .....	3
2. EQUIPMENT NEEDED .....	4
3. MECHANICAL ASSEMBLY .....	6
4. REPLACING PHOTO CELLS ON JAMISON/BMP DOOR .....	9
5. CONTROL PANEL OVERVIEW .....	10
6. CONTROL CARD TERMINAL FUNCTIONS .....	11
7. LED FUNCTION .....	12
8. CURTAIN INSERTION .....	13
9. SETTING UP THE SAFETY SYSTEM (UNROLL SENSOR) .....	15
10. SETTING UP THE SAFETY SYSTEM (REVERSING EDGE).....	15
11. PROGRAMMING DOOR LIMITS .....	18
12. SETTING THE OPEN AND CLOSE POSITION.....	19
13. PEDESTRIAN OPEN POSITION SETUP.....	20
14. RADIO CONTROL RECEIVER BEFORE 10/23/18 .....	22
15. RADIO CONTROL RECEIVER AFTER 10/23/18 .....	22
16. PROGRAMMING RADIO CONTROL RECEIVER .....	24
17. HEATER WIRING CONNECTIONS .....	25
18. PRE-WIRING CONNECTIONS .....	26
19. DIP SWITCH SETTINGS .....	27
20. MANUAL OPERATION.....	28
21. MISCELLANEOUS OPERATING INSTRUCTIONS .....	29
A. Battery Backup .....	29
B. Power Failure with no Battery Backup.....	29
C. Using Automatic Rethreading Feature .....	29
D. Motor Brake Air Gap Adjustment.....	29
22. PERIODIC CHECKS AND MAINTENANCE.....	30
A. Ordinary cleaning and inspection.....	30
B. Planned inspections and maintenance .....	30
23. TROUBLE SHOOTING .....	31
24. ERROR CODES.....	32
A. LED Display Code Key .....	33

# 1. INSTALLATION OVERVIEW

- **NOTES:**
  - Please use this booklet as a step by step installation guide.
  - This book contains instructions for several different door configurations. Some sections may not be apply to your particular installation.
- **CONTENTS OF CRATES AND CARTONS**
  - Unit is shipped in one crate
  - Control panel key is in the control panel
  - There is one box of miscellaneous hardware which will include hardware and electrical options
- **INSPECT FOR DAMAGES AND/OR SHORTAGES IMMEDIATELY**
  - Open all shipping containers and inspect for concealed damage and/or shortages. Carefully repack to prevent further damage and pilferage.
  - Note on all copies of the delivery receipt any damages and/or shortages.
  - If shipping damage occurred, report it in writing to the transportation company. Refer to Jamison's Terms & Conditions Form 166.
- **HANDLE ALL PARTS CAREFULLY**
  - Certain parts such as gaskets, wiring, etc. are vulnerable to damage.
- **READ ALL INSTRUCTIONS BEFORE PROCEEDING WITH THE INSTALLATION**
  - Instructions include basic drawings and schematics. These instructions and any other documents are included with this shipment.
  - Refer to job drawings for special features.
- **PLAN AHEAD**
  - Choose installers who are Millwrights or have equal qualifications.
  - Have all tools and materials necessary for installation readily available.



- **Before any service, personnel must be properly trained and be qualified to work on the equipment.**
- **Working on the electrical equipment requires special training and no one should work on the electrical equipment without proper certification.**
- **Before doing any electrical work be sure the power to the door is turned off, locked and tagged out.**
- **Be sure installing personnel fully read and understand the manual prior to installation.**
- **Block off the area from traffic and place signs indicating the door is out of operation and personnel are in the area working**
- **Unauthorized people must not repair or maintain the door and should not be in the area during maintenance.**
- **Do not use any heat sources that could start fires near the door and do not solder during maintenance.**
- **Do not use compressed air or any solvents on the door.**

## 2. EQUIPMENT NEEDED

1	Tape Measure	10	Level
2	Suitable equipment to lift and access the parts of the door (ladder, forklift, man lift, etc.)	11	Wrenches, SAE and Metric
3	Screwdrivers – small precision screwdrivers and Phillips	12	Voltmeter
4	Cordless Drill	13	Hammer
5	Tools to install the wall fasteners. Each install is unique so be sure you have what you need for your wall.	14	Grinder
6	Drill bits appropriate to wall construction and thickness	15	Caulk Gun
7	Scissors	16	Pliers
8	Wire Stripper	17	Allen Keys, SAE and Metric
9	Clamps	18	3/8 Concrete Drill Bit + Hammer Drill



Man Lift



Fork Lift



**The manufacturer may change this manual at any time without notice. The pictures in this manual may not fully represent the actual product and are meant for illustrative purposes to assist installation.**

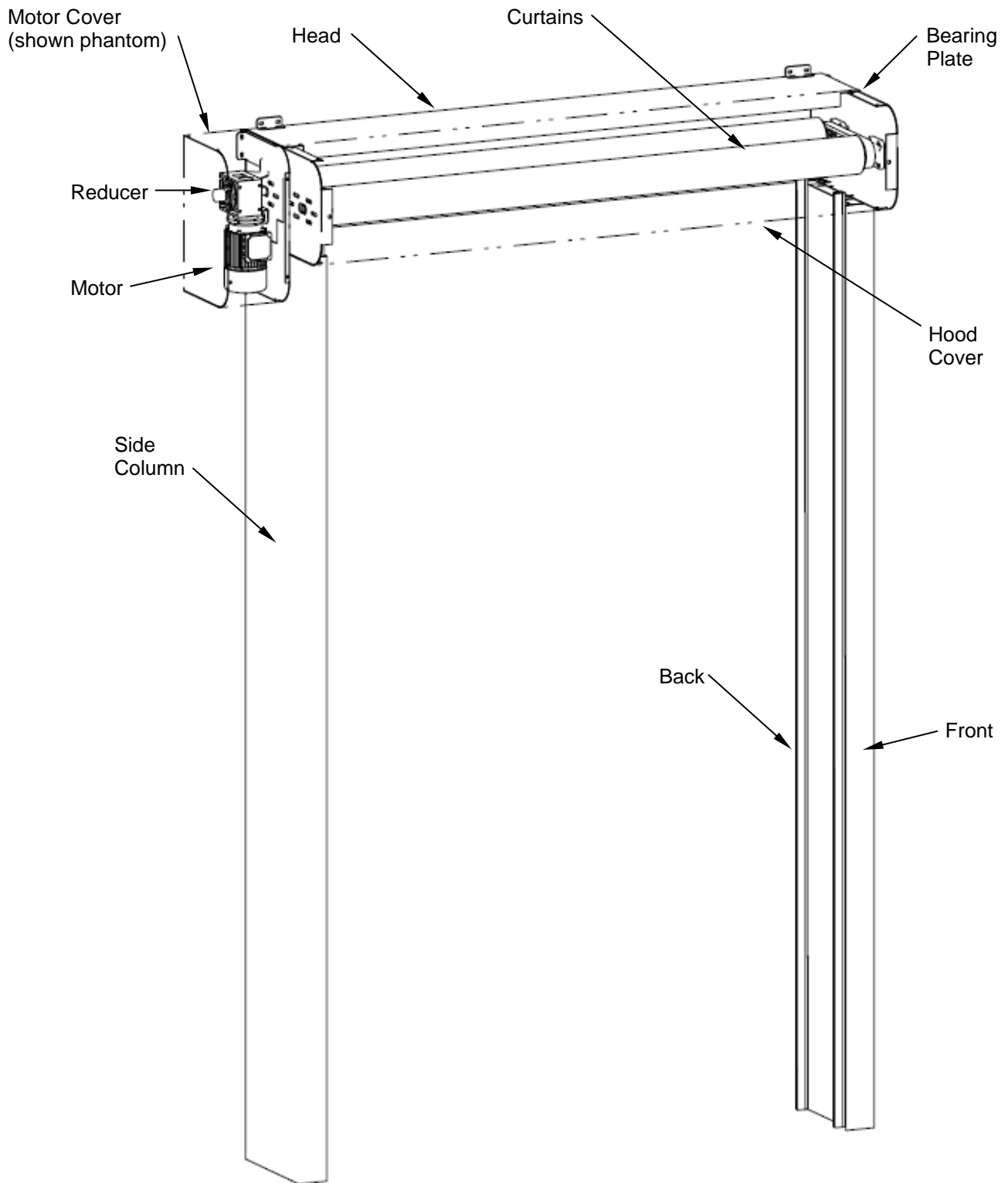

### 3. MECHANICAL ASSEMBLY

- Remove the head and side frames from the crate.
- Remove the covers from the side columns.
- Lay the side columns and head on a flat level surface in front of the opening on the side of the opening to which the door will be attached. This needs to be a location from which the door can be lifted and moved to the opening assembled.
- Attach the side columns to the head using (4) carriage bolts (two per side) as shown. For initial positioning align the outside edge of the side frame to the outside edge of the bearing plate.

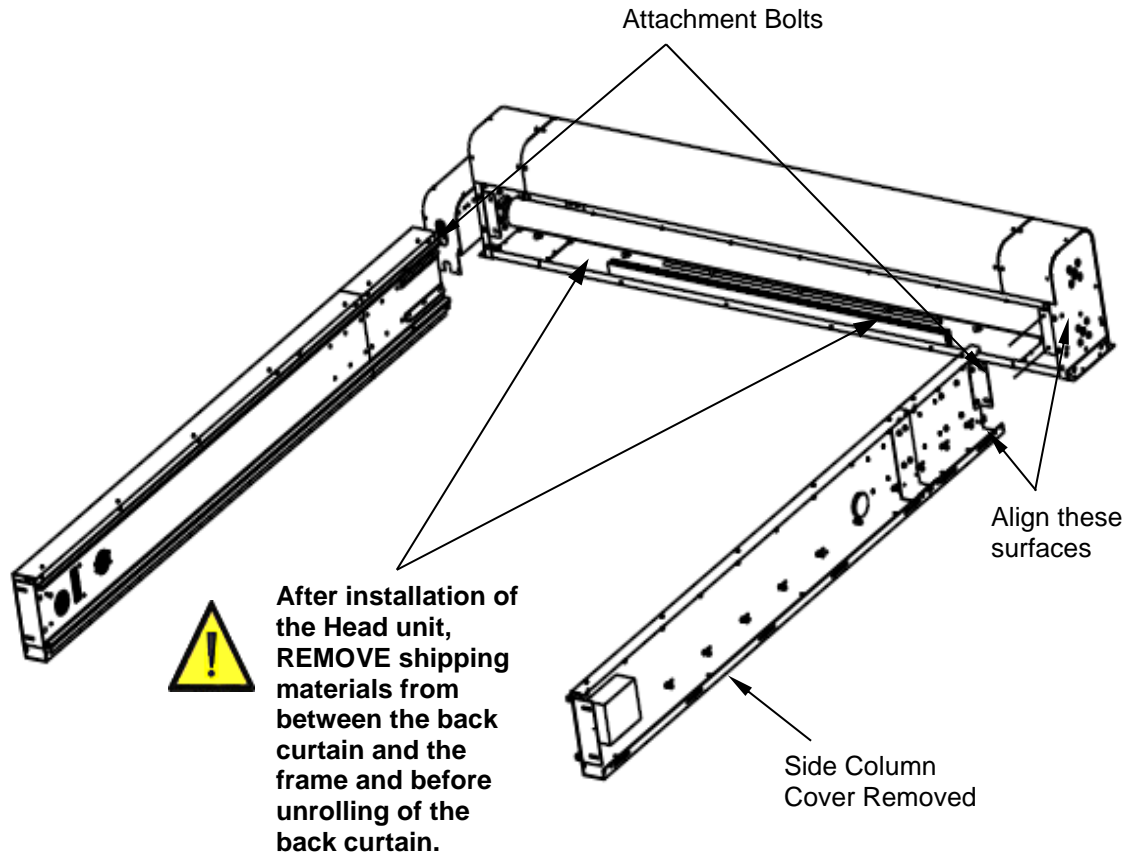

- **If you have inside trim, please see drawing H4487213 before continuing with the door installation**
- Remove the motor cover from the side of the unit and put it in a safe location to prevent damage, it will be reinstalled later.
- Lift the assembled unit into place using a fork truck or similar lifting apparatus. You will need assistance in guiding the legs while it is being lifted to prevent damage to the unit.
- Position the unit in the opening so that it is centered with the edges of the opening approximately lined up with the inside edges of the HDPE track.
- **UNTIL THE UNIT IS SECURED TO THE WALL IT IS UNSTABLE. KEEP THE LIFTING APPARATUS IN PLACE WHILE LEVELING AND SECURING THE DOOR. SERIOUS INJURY COULD OCCUR IF THE UNIT WERE TO FALL.**
- Check the level of the head of the unit and make adjustments as needed. Shims under the front and back of the side columns may be required, do not put shims under the floor bracket.
- Once the head is level and centered secure the head to the wall. There are two holes in the bearing plate opposite the motor, one in the motor bearing plate and two brackets at the top corners of the unit. **DO NOT REMOVE THE LIFTING APPARATUS. Remove shipping materials (wood & vinyl) between back curtain and frame.**
- Loosen the bolts holding the side columns to the head and unroll enough curtain to get it started in the HDPE track (See the back of the manual for information on manual operation).
- Adjust the position of the top of the side column to put a slight tension on the curtain. The springs supporting the track should compress .125 - .25". Before tightening be sure the side column is square to the wall, check that the distance between the inside of the HDPE track is approximately the same for both the front and rear curtains, re-tighten the bolts holding the side column to the head.
- Plumb the side columns and set the distance between the HDPE track at the bottom the same as it is at the top.
- If necessary, loosen the feet of the column so they can be lowered to the floor and secure them to the floor using concrete anchors. Be sure to put the anchor in the center of the slot to allow for final adjustment later. Tighten the the bolts securing the feet to the side column.
- Secure the side frames to the wall by drilling in the center of the slot in the side frame to allow for final adjustment later.
- The lifting apparatus can be removed once the door is secured to the wall.

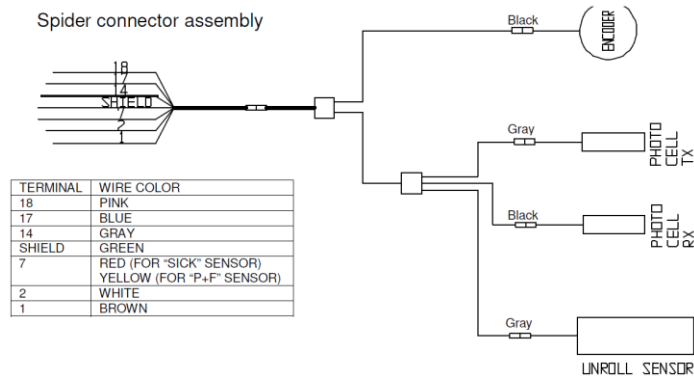



- Install the photocells in the side columns in the holes provided being sure that the photo cell with the “Photocell T” labeled cable is installed in the non-motor side side frame and the photo cell with the “Photocell R” labeled cable is installed in the motor side side frame.
- **Note that one photocell is installed in front of the UHMW track and one is installed in the back.**
- Route the cable from the head through the hole in the top of the side column and attach the connector to the photocell cable.
- Secure the cable in the side frame using cable ties or other appropriate fastenings, **do not wrap the wire around the springs as this will eventually cause damage to the wire.**

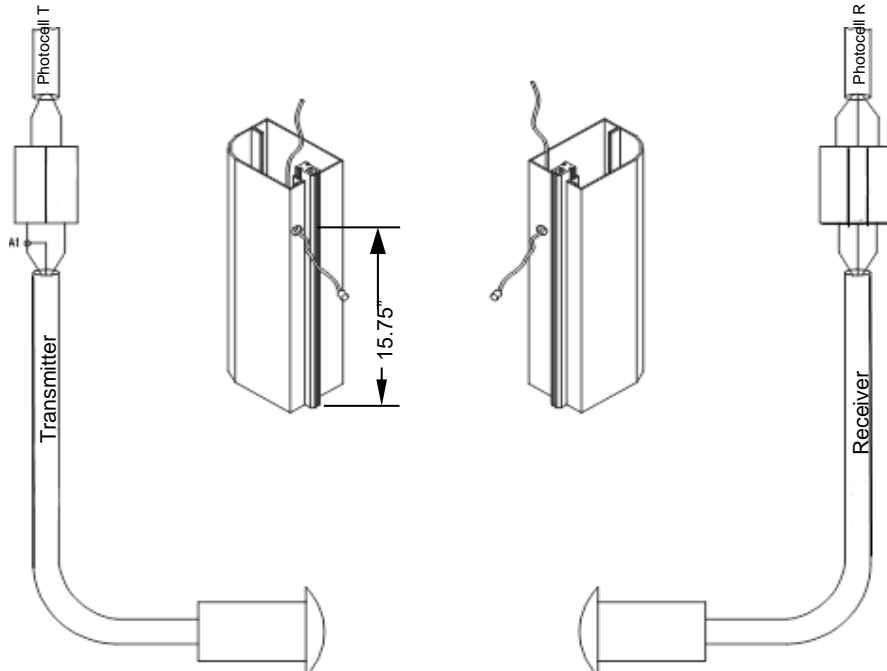
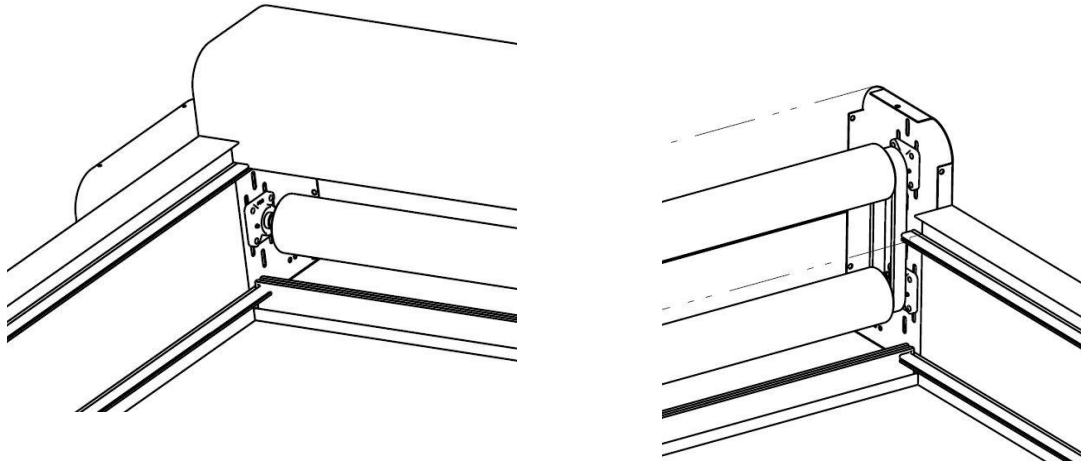

- If there are other photocells near the door they may interfere with the operation of this door’s photocells



## 4. REPLACING PHOTO CELLS ON JAMISON/BMP DOOR



Install tie wrap snug around the barrel of Photo the cell



Gently slide tie wrap over retainers of Photo cell



Push Photo cell through hole



Remove Photo cell

## 5. CONTROL PANEL OVERVIEW

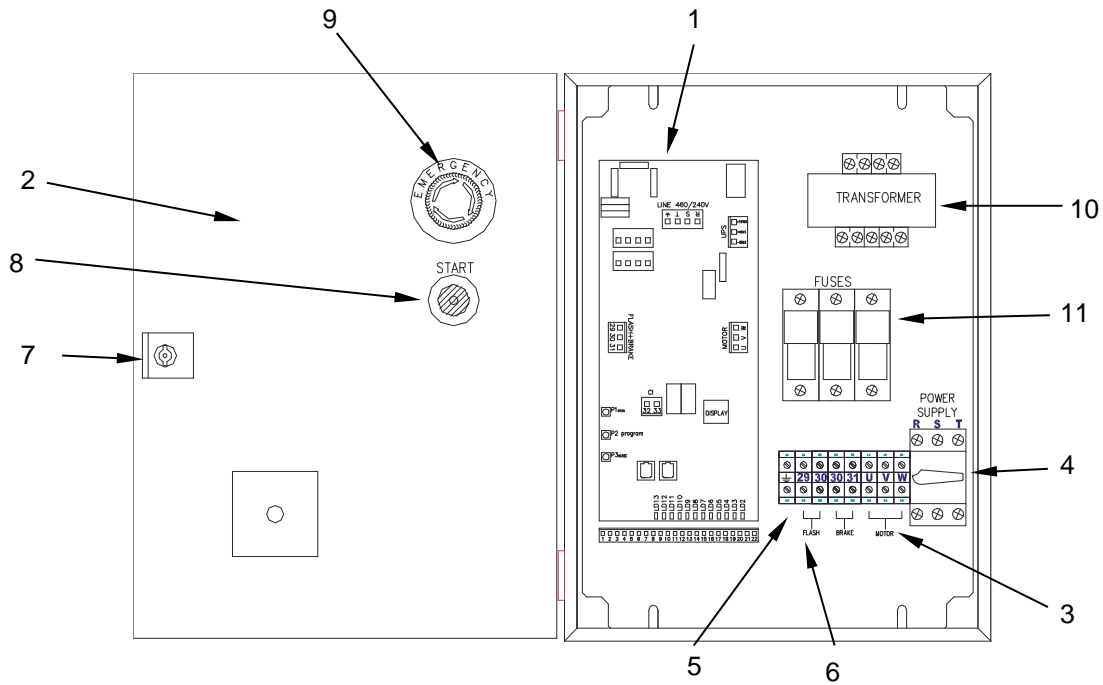

1	Control card	6	Brake 30-31, Flashing light 29-30
2	Cover	7	Enclosure cover lock
3	Motor terminals	8	Start button
4	Power switch	9	Emergency stop button
5	Grounding terminal	10	Transformer
		11	Fuses 15A

## 6. CONTROL CARD TERMINAL FUNCTIONS

Terminal	Function
1	12VDC+ 500mA max
2	DC neutral
3	LED Countdown timer
4	Door closed signal output, closed when door is closed, open when door is not closed
5	
6	Same as 1
7	Safety sensor NC contact with delay (unroll sensor)
8	Open only input, NO
9	Safety sensor instantaneous NC contact (reversing edge)
10	Not used
11	Open/Close input, NO
12	Pedestrian open input NO
13	Same as 1
14	Photocell input, NC
15	Same as 1
16	Stop button input, NC
17	Encoder signal
18	
19	Open over travel switch, NO
20	Close only input, NO (future option)
21	24VAC 700mA source for accessories
22	24VAC neutral
23	Three phase power to motor, change rotation by changing wires on this connector.
24	
25	
R	Three phase power to control card
S	
T	
PE	Three phase PE ground
29	Flashing light output, 230VDC/460VDC
30	DC neutral for 29 and 31
31	Motor brake power, 105VDC
32	Door open signal output, closed when door is open, open when door is not open
33	

## 7. LED FUNCTION

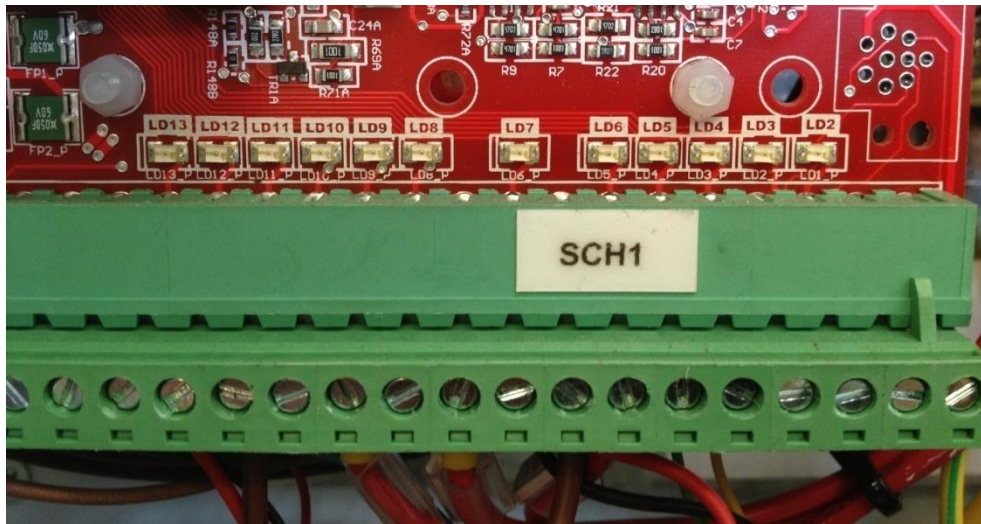

LD1	Card status LED, in operation blinks about every 4 sec, programming mode flashes about 500ms
LD2	Close only contact, lit when activated, T20 (future option)
LD3	Open overtravel sensor, lit when blocked, T19
LD4	Encoder status, flickers while door is in motion but may appear to be on, off at other times, T18
LD5	Encoder status, flickers while door is in motion but may appear to be on, off at other times, T17
LD6	Stop button, must be on for door to operate, T16
LD7	Photo eye, off when the photo eye is blocked, on when it is not blocked, T14
LD8	Pedestrian push button, on when the button is pushed, T12
LD9	Open/Close input, on when open/close device is activated, T11
LD10	NA always off
LD11	Safety sensor wired into T9, must be on for the door to operate. If no accessory is wired in, must have a jumper
LD12	Open only input, on when open only device is activated, T8
LD13	Safety sensor wired into T7, must be on for the door to operate. If no accessory is wired in, must have a jumper

## 8. CURTAIN INSERTION



**Any electrical work must be done by qualified and knowledgeable personnel, serious injury or death could result if work is done by unqualified personnel.**

- It is easiest if power is connected to the door before inserting the curtain. See wiring diagram H4487181 for the location for landing power and ground. The following assumes that power is available, if not the door can be operated with the manual crank instead of the control panel.
- Before connecting power to the control panel check the control transformer setting to be sure it is set for the line voltage you will be using, if it is wrong correct it by moving the wire to the appropriate voltage. If this is incorrect also check the motor wiring to be sure it is correct, see page 22.
- Jog the door closed using P3, if the door rotates in the wrong direction correct the motor rotation by reversing the wires on terminals 23 and 24 at the center-right of the control board.
- Jog the door closed so that it overlaps the black track by about 5"
- Pull the top of the black track toward the opening and insert the curtain.
- Once both sides of the curtain are in the track use P3 to jog the door to the fully closed position. The jog buttons only move the door a few feet even if they are held so you will likely have to push and hold them more than once to get the door fully closed.

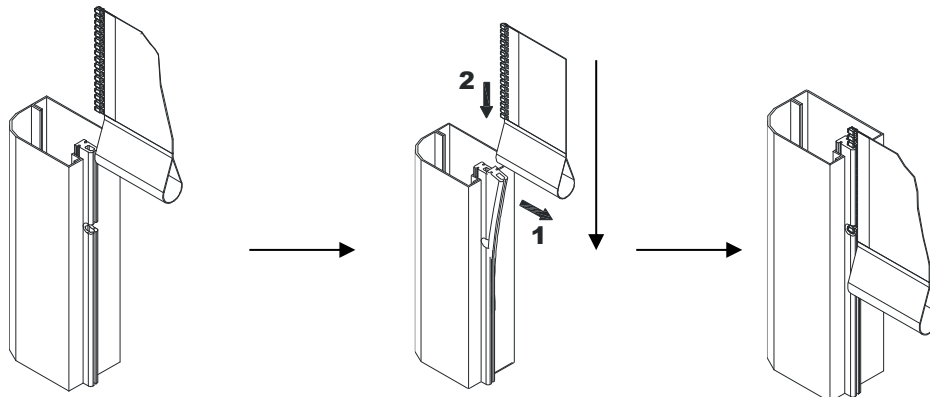
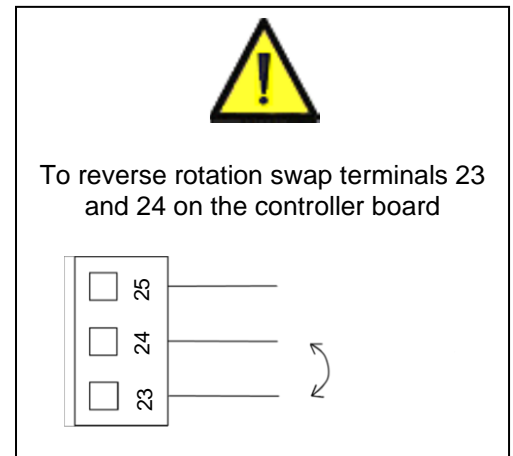
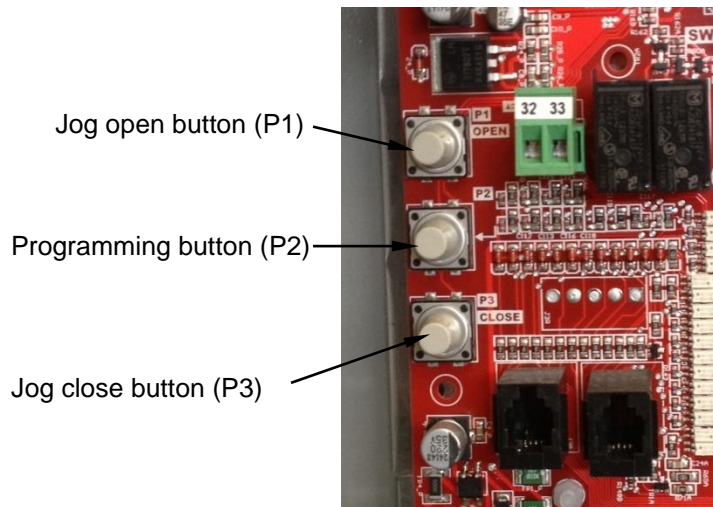

- Loosen the side column attaching bolts. Adjust the bottom of the side columns by sliding them away from the opening to stretch the curtain. The springs holding the track should compress .125 - .250"

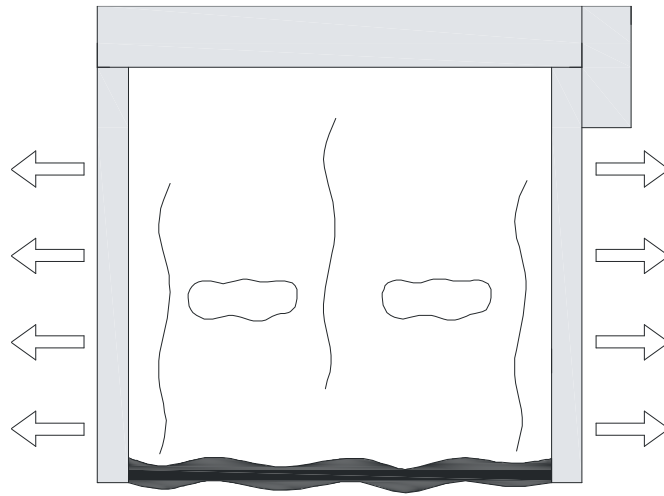

- Check that all the springs have similar compression and that the side columns are square to the wall.
- Re-tighten the attaching hardware.
- Use the jog buttons to run the door up and down to be sure it operates smoothly.
- If the door does not travel to the bottom on its own it may be necessary to loosen the side columns and operate the door a few times full open and closed and then resecure the side columns.
- **Caulk around the inside and the outside of the unit where it touches the wall. This is required to prevent condensation on/in the unit.**

## Curtain Adjustment

- If the curtains do not touch the floor simultaneously they will need to be adjusted.
- Jog the door closed so that the longest curtain just touches the floor.
- Turn off the power to the door.
- Remove the hood covering the curtains
- Remove the master link in the chain on the side of the drum away from the power unit and unroll the shorter curtain so that it just touches the floor.
- Reinstall the master link in the double chain.
- Turn power on to the door, readjust as necessary and check operation.



## 9. SETTING UP THE SAFETY SYSTEM (UNROLL SENSOR)

- Before proceeding check to see if LD13 is on, if it is then you can skip the programming of the reversing edge and proceed to “Programming the door limits”
- The unroll sensor should be plugged into the designated wire on the spider connector shown on the wiring diagram included in your packing materials.
- The red end of the unroll sensor should be 10mm away from the bearing plate towards the curtain. If it is not, loosen the two nuts, relocate it, and tighten the nuts.
- If LD13 is off, then the sensitivity needs to be turned down. This is done by rotating the phillips head seen in the figure below, counterclockwise, until LD13 turns on. If the sensitivity is not high enough, rotate the same screw clockwise.

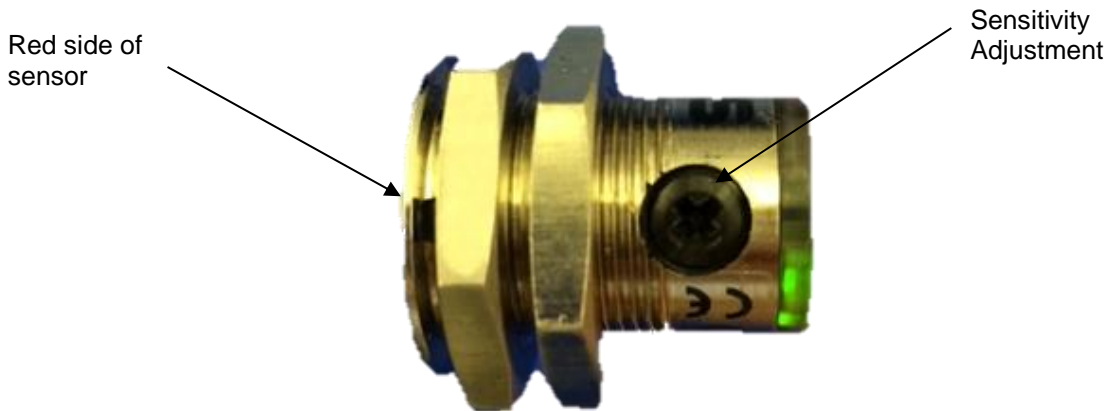

## 10. SETTING UP THE SAFETY SYSTEM (REVERSING EDGE)

- Before proceeding check to see if LD11 is on, if it is then you can skip the programming of the reversing edge and proceed to “Programming the door limits”
- There are three components to the reversing edge, a receiver, a transmitter and the edge itself. The edge is battery operated and the battery must be installed for it to work properly.
- There is a pocket in the bottom of the door that is closed with Velcro, locate the pocket and pull the transmitter out of the door being careful not to pull the edge out of its pocket. There will be enough extra wire for you to do this.



- Be sure the receiver is wired to the control panel. If your door is prewired then it will already be wired to the control panel, if not then you will need to wire it to the panel as shown below. **The maximum distance between the transmitter and the receiver is 25 ft.**

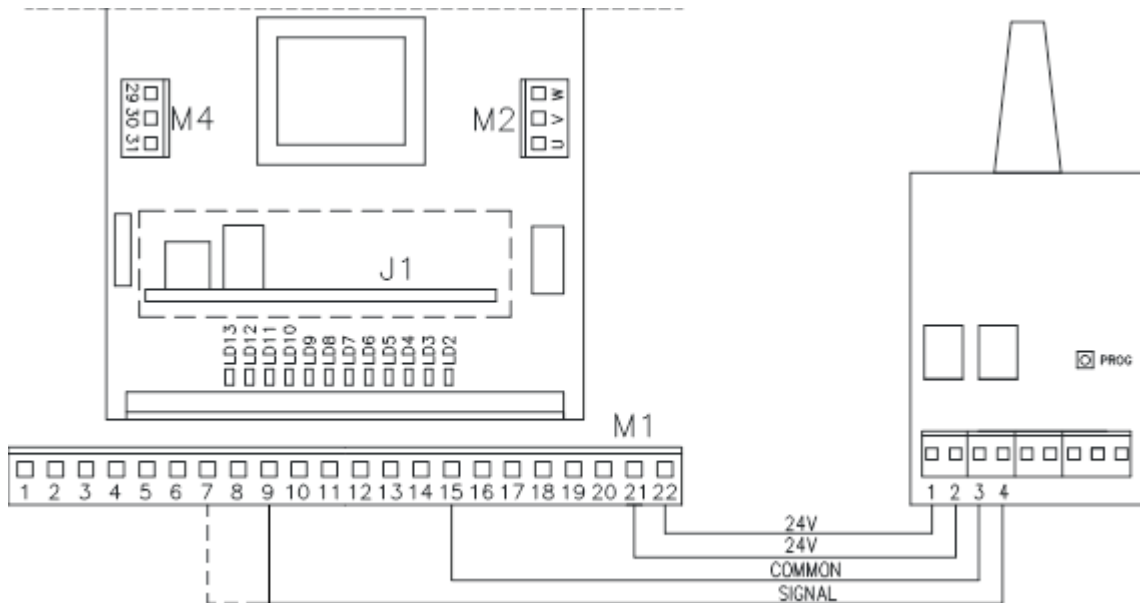

**For 868 MHz units:**

- Be sure the jumper is only on one pin for resistive edges and on both pins for pneumatic edges and the batteries are installed.
- Place the MR jumper on both pins in the receiver.
- Press and hold the program button in the receiver until you hear it beep fast. Initially it will beep at 1 sec intervals.
- Once the receiver stops beeping, press the program button in the transmitter until you hear another beep in the the reciever.
- Wait 10 – 15 seconds and the LED LD11 will light, this indicates that the programming of the edge was successful. If LD11 does not light then repeat the procedure.
- Push up on the bottom of the door and LD11 in the control panel should go off.
- The edge is working correctly, put the cover back on the transmitter and put it back into its pocket

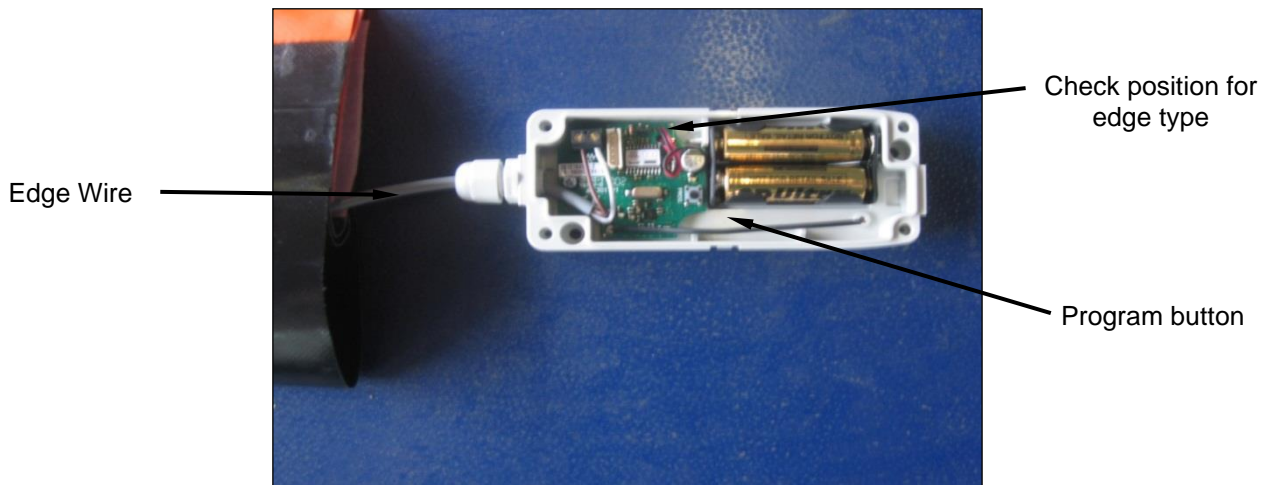



**For 916 MHz units:**

- Be sure Dip Switches “1” & “2” are set to “ON” for pneumatic edges (Safety contact NC) in the transmitter and Dip Switch “3” is set to “ON” in the receiver.
- Be sure two batteries(3.6V, ER14505) are installed in the transmitter.
- Press “PROG” button on the receiver (1) until R1 LED lights (2).
- Press “PROG” button on the transmitter (3).
- A beep will be heard on the receiver indicating the transmitter is properly programmed (4).
- To exit programming mode, wait for 10 seconds or press “PROG” button on the receiver. Two beeps will be heard.

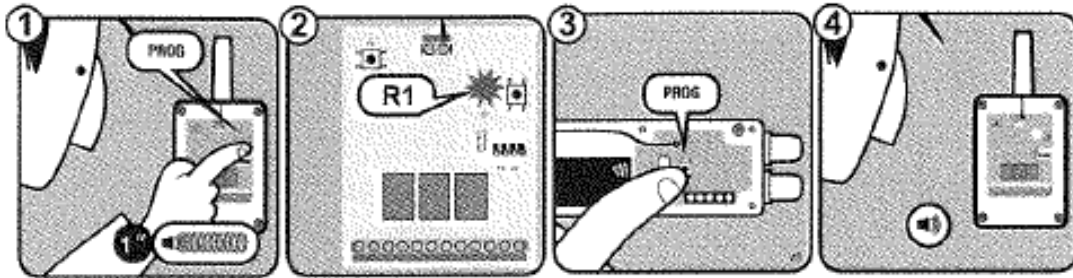
**For iGAZE units:**

- Check that Dip Switches “2” & “3” on the transmitter and Dip Switches “3” & “4” on the receiver are set the same direction.
- Press and keep pressed the programming/reset button on the receiver until it emits 1 beep then release.
- Press and keep pressed the programming/reset button on the transmitter relative to used input, (Prog./Test1 for safety edge 1, Prog./Test2 for safety edge 2), until it emits 2 beeps then release.
- Programming has been completed.

## 11. PROGRAMMING DOOR LIMITS

- Use the Jog Close button P3 to jog the door to the closed position if it is not already there. The two pictures below show the correct sill compression (left) and the incorrect overcompressed sill (right)
- To get the sill perfectly set it may be necessary to manually operate the door. Instructions for this are given toward the end of the manual. Since there are two curtains it may be necessary to slightly over compress one of the sills to get the proper seal on both.

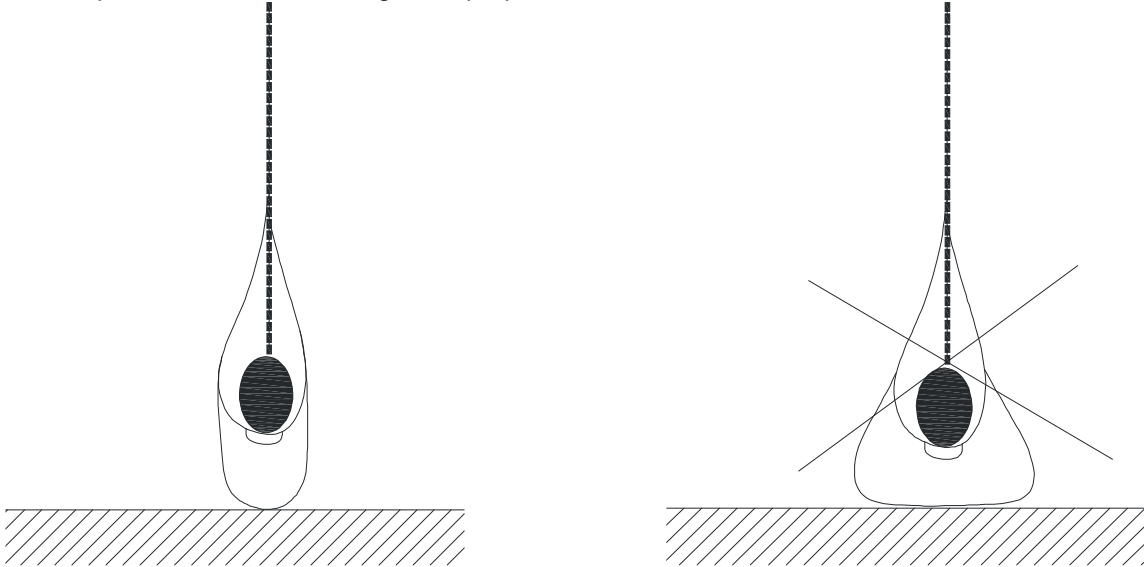

## 12. SETTING THE OPEN AND CLOSE POSITION

- The door should already be closed. Press and hold the Programming button P2 until the Card Status LED begins to flash quickly.

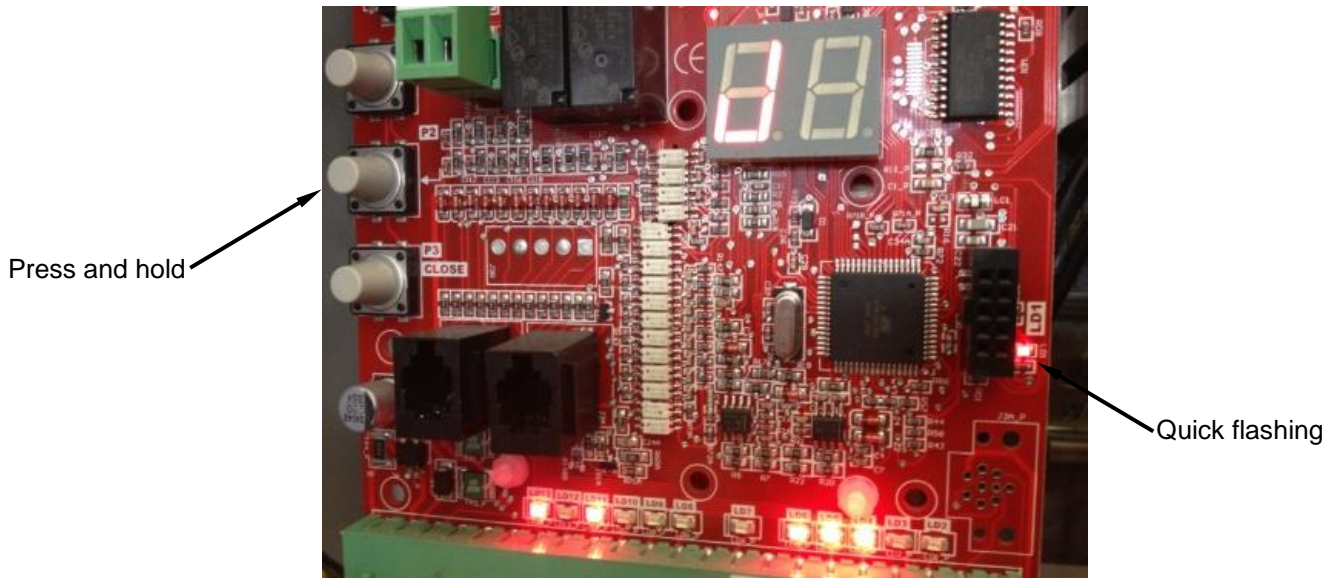

- Within 5 seconds, press the Jog Open button P1 to open the door to the open position. Please note that when the door is open the two curtains may be off in the open position by several inches, this is normal. The figure below shows the correct position of the door bottom is even with the rethread slot.

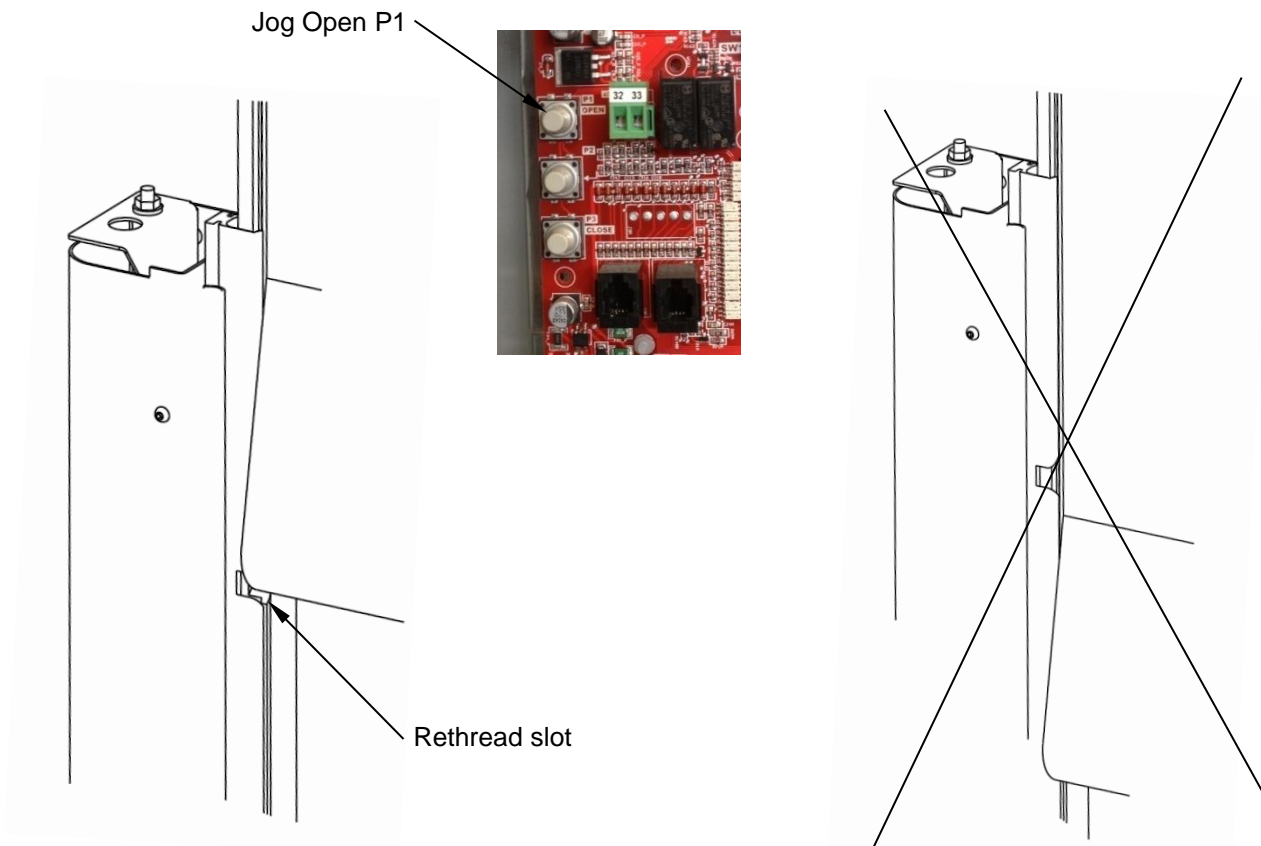

- With the door in the open position push P2 to set the position and then push P2 again to set the amount of time delay for closing. The time between the first push of P2 and the second push will be the amount of time delay.
- The door will move to the home position at the photo eye.

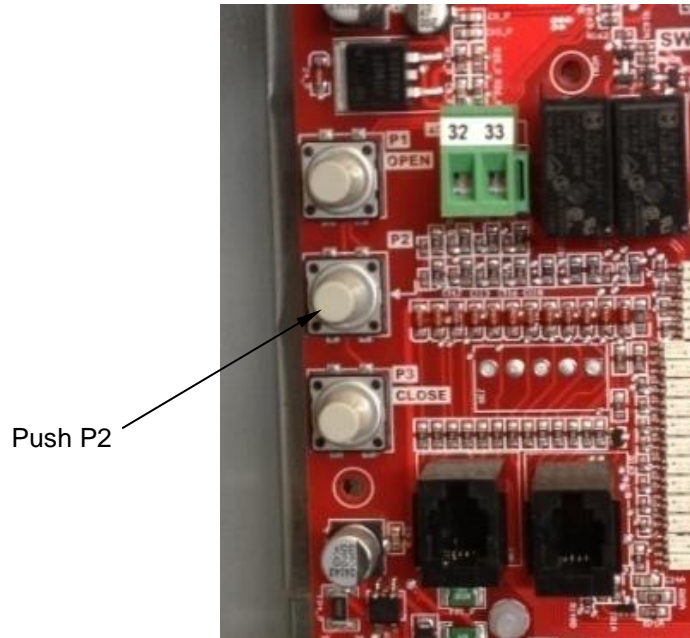

- Push the start button on the front of the panel and the door should move to the open position
- Push the start button again (or allow the time delay to close the door) and the door will close and is ready to use.

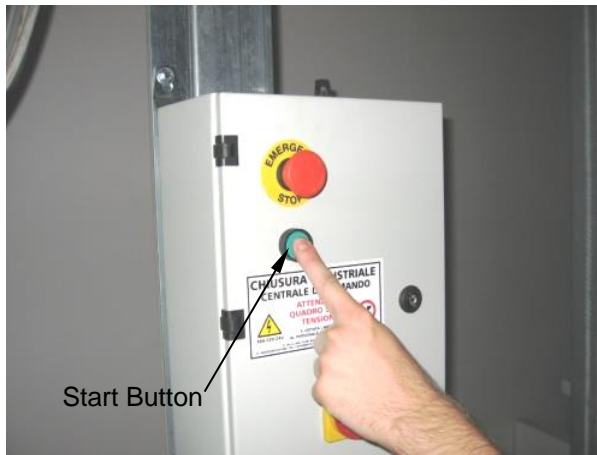

## 13. PEDESTRIAN OPEN POSITION SETUP

- The door should already be closed. Press the Jog Open button P1 to move the door to the desired position for pedestrian open.
- Press and hold the Programming button P2, the Card Status LED (LD1) will flash quickly, and "tE" or "tA" will show on display.

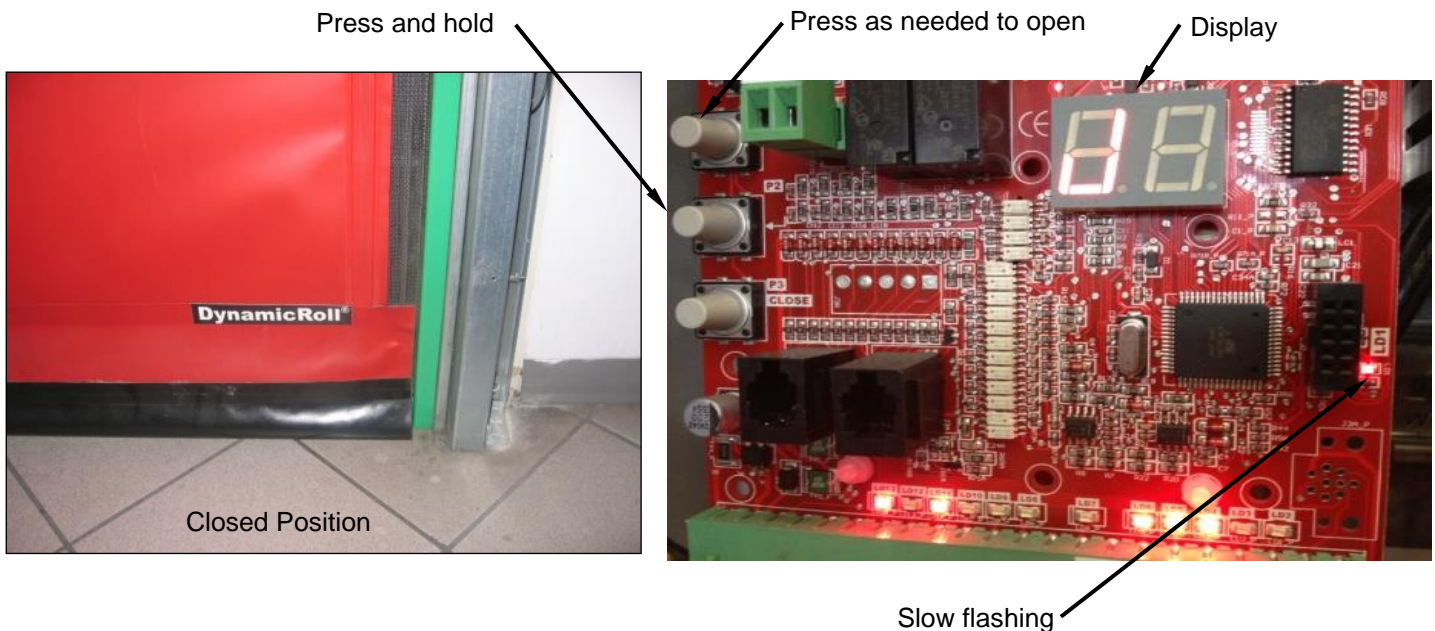

- Within 5 seconds push the pedestrian open button to set the pedestrian open position, "tP" will display, then push it again to set the time delay, "PE" will display.
- The time between the first push of the start button and the second push will be the amount of time delay.
- Push button a third time to complete the procedure or wait a few seconds for unit to self complete.
- Cycle door several times, pedestrian open cycles and full open cycles.

NOTE: Full open time delay and pedestrian open time delay share the same time delay setting.

## 14. RADIO CONTROL RECEIVER BEFORE 10/23/18

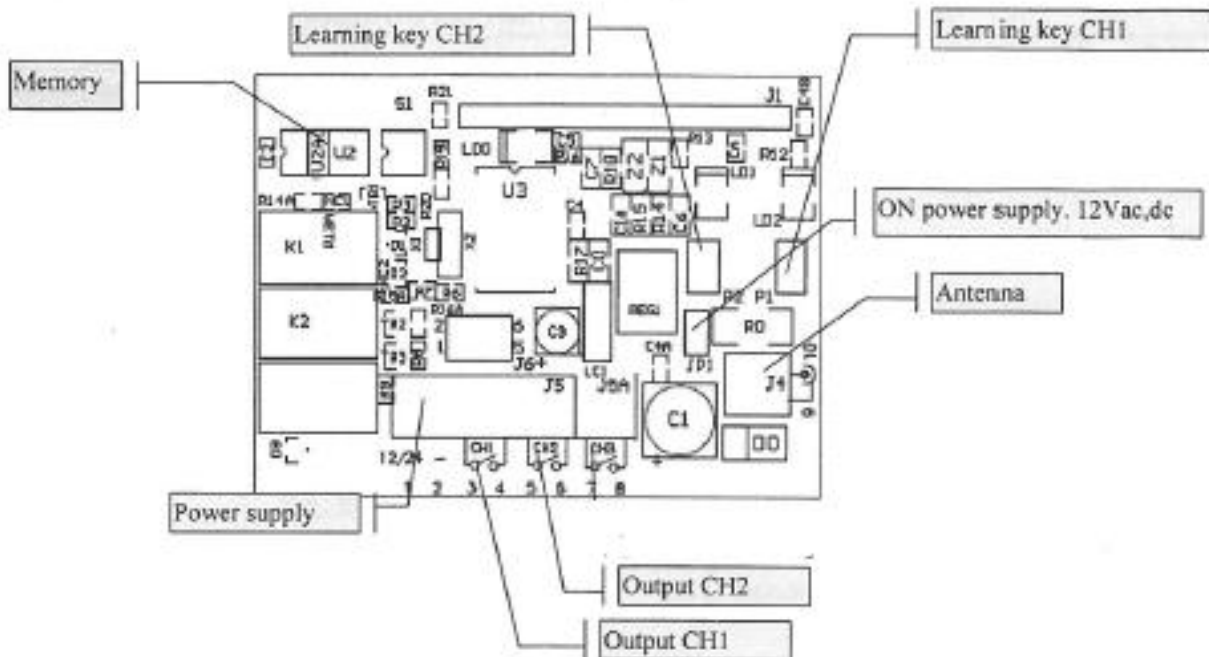

### Radio Control Setup

- **Note:** Disconnect output wiring on terminals 3, 4, 5 and 6 during programming.
- This is a two channel transmitter. One door uses the left button with its output on terminals 3 and 4. The second door uses the right button with its output on terminals 5 and 6.
- Setting Codes: Be sure DIP switches S1 and S2 are in the down position.
- For channel 1, press and hold the channel 1 learning key P1 in until the LED LD2 illuminates and then within 3 seconds press and hold the button on the transmitter that you want to use to control the door until LD2 blinks (should be almost immediate). As soon as LD2 blinks release both buttons. To test the programming push and release the button on the remote control (to generate the signal the button must be held for about a second) and LD2 will light while the button is held,. Channel 1 now is programmed.
- The contact for this button is between terminals 3 and 4 in the receiver. This is a dry contact and will close when the button is pushed.
- Channel 2 programming is similar except the learning key is P2 and the indicator light is LED LD1
- Clearing codes: this will erase all codes stored in the receiver and you will need to reprogram them afterwards.
- Press and hold the channel 1 learning key P1 until LED LD2 comes on and then goes out. Release button. At this point LEDs LD1 and LD2 illuminate. After 7 seconds LEDs LD1 and LD2 turn off indicating the memory is cleared.



## 15. RADIO CONTROL RECEIVER AFTER 10/23/18

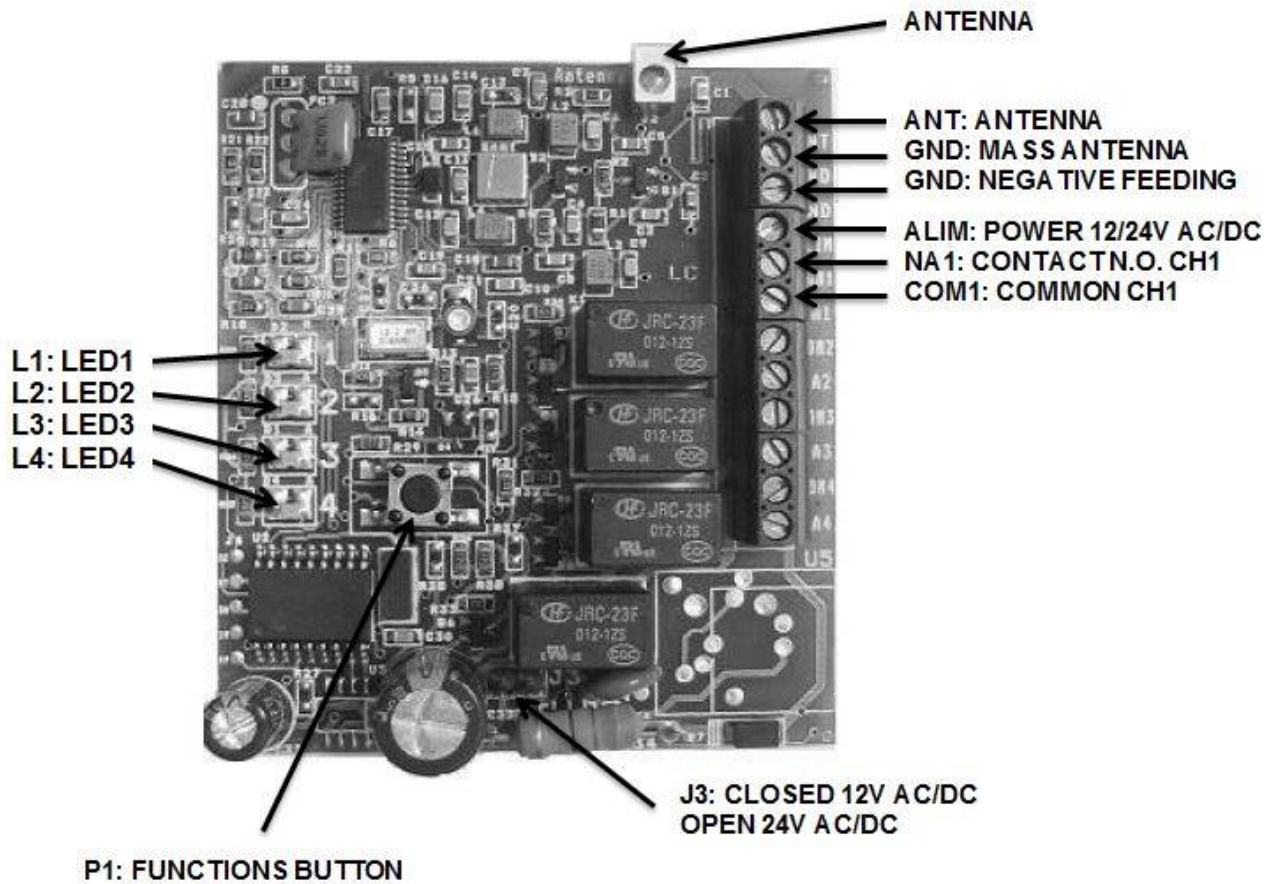
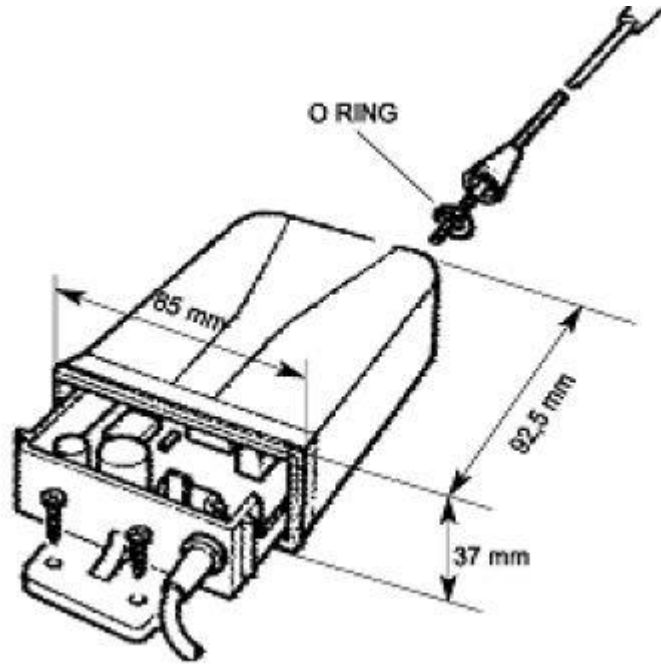

## 16. PROGRAMMING RADIO CONTROL RECEIVER

Unscrew antenna and remove cover from receiver as shown on previous page.

Reinstall antenna onto receiver without the cover.

Push button in receiver until LED #1 comes on.

Push and hold button on remote control until LED #2 and #3 blinks on the receiver.

Release button. (For the next 13 seconds you can program additional remote controls, by pushing the desired button and watching LED #2 and #3 blink.)

After your last remote, push the button on the receiver and LED#1 will go out.

### **Deprogramming a remote**

Push the button on the receiver for approximately 3 seconds until the LED's #1,2 and 3 begins to blink.

Press and hold the button on the remote until the LED's stay on solid.

Push the button on the receiver, LED's go out.

For completely clearing the receiver, push the button in the receiver for about 6 seconds until LED's #1,2 and 3 come on solid.

Release the button.

If the memory is full during the storage phase the four LEDs will switch off and on in sequence and then switch off. Completely clear the receiver and start over.



## 17. HEATER WIRING CONNECTIONS

- **Before making the heater connections be sure that all power is disconnected from the heater circuit and the circuit is locked and tagged out.**
- Depending on the conditions you have there may be 1 or 2 heat circuits. The main heat connection is DIN Rail mounted on the motor side above the motor . You can determine the number of circuits in your unit by checking the number of terminal strips. Two terminal strips per circuit. The terminal labels are for the following.
  - X1/X3 – Recirculatory heater circuit
  - MHT L/MHT N – Motor heat circuit
- If the ambient temperature of either side of the door is less than 40F, then recirculatory heaters are needed. They are adjustable and are installed in the bottom of each side column.
- If the temperature of either side is below 32F, then frame heaters are required. Depending on the size of the door and the voltage there can be one or two heater circuits.
- Maximum Power Requirements (specific applications may be less, check the wiring diagram H4487346 or H4487347 for the specific requirement for your unit.
  - 120 VAC – max fused load 60A
  - 208/230 VAC – max fused load 30A
- 120VAC is used for 460VAC applications.
- Recirculatory Heater Connections
  - The wiring for the recirculatory heaters is connected to the heater enclosure and is shipped stowed in the head at each end. When recirculatory heaters are used they are always used in pairs.
  - Unroll the wires, feed them through the bearing plate and down the side column to the recirculatory heater. Secure the wiring in the side column, do not attach the wiring to any moving parts including the springs.

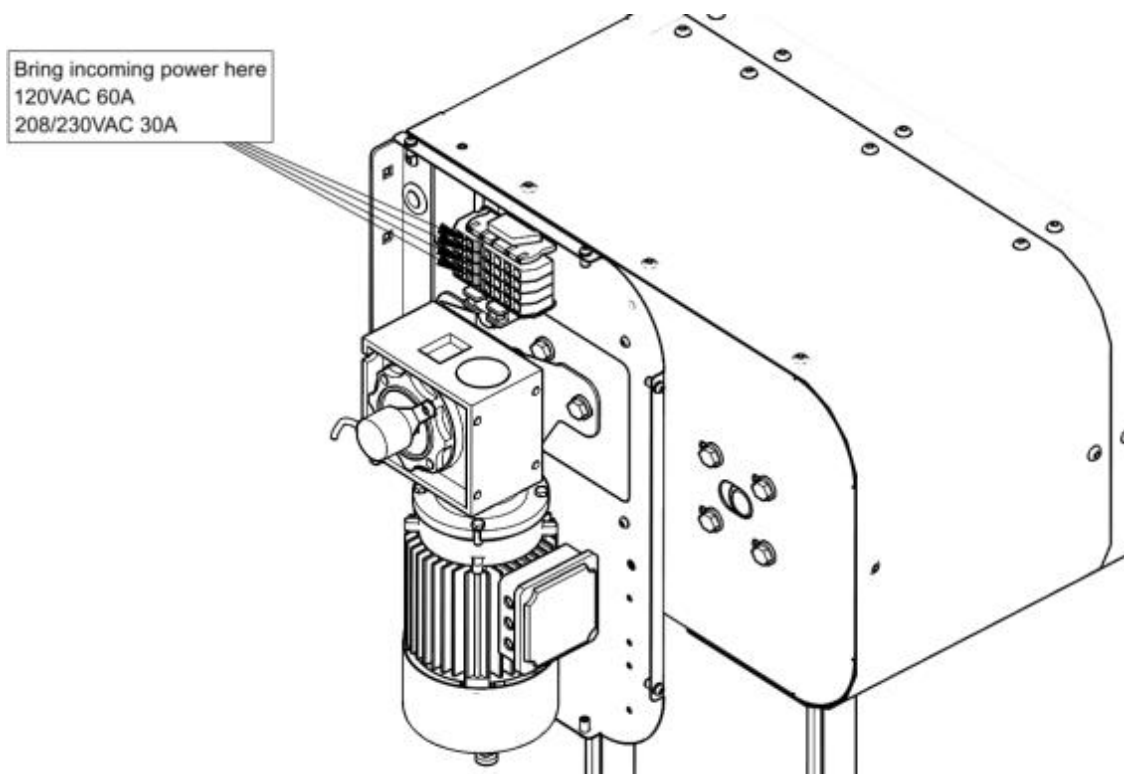

## 18. PRE-WIRING CONNECTIONS

Pre-wiring connections for 240VAC

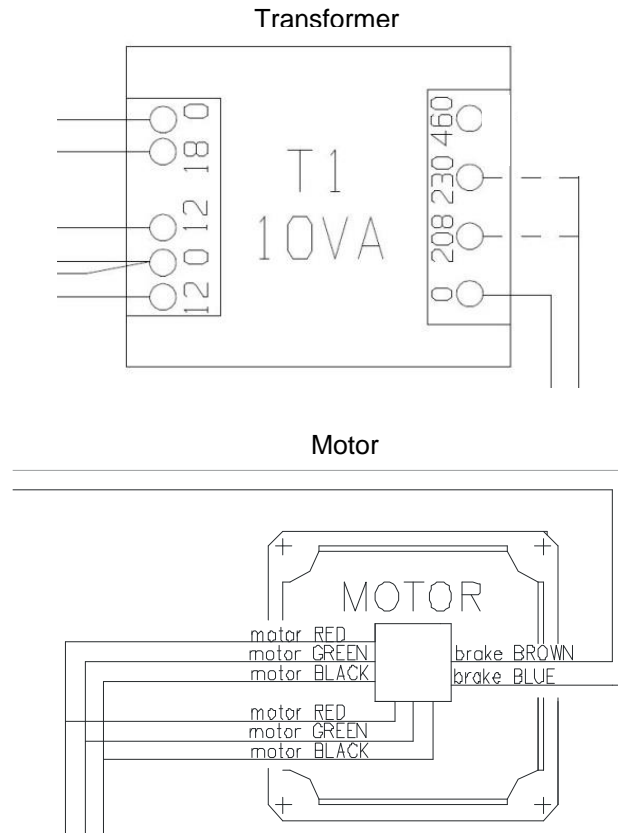

Pre-wiring connections for 460VAC

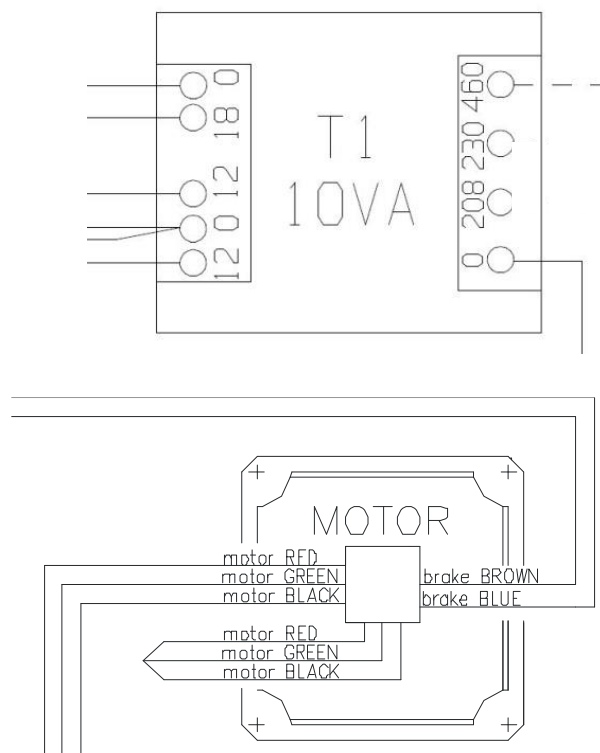

## 19. DIP SWITCH SETTINGS



Time delay closing: to activate this function turn dip switch 1 to ON, to disable set dip switch 1 to OFF. If dip switch 1 is off then the door will not close automatically.



Motor dynamic braking: This is used only with doors that have a counterweight to open them in case of a power failure. To turn on dynamic braking set dip switch 2 to ON, to disable turn dip switch 2 OFF.

### Door adjustment after programming

After the initial programming of the door, run the door full speed open. If the limits aren't perfect, use the following set of instructions to adjust parameters.

#### Motor Type Adjustment (Software 01160501 and newer)

Close the door and push in the stop button and then hold the P2 programming button. Instead of going into regular teach mode (display TE) it will go into limit programming and display alternating "No" and a number. This chooses the motor type. **(THIS SHOULD NOT BE DONE UNLESS INSTRUCTED TO DO SO BY JAMISON TECHNICAL SERVICE)**

#### Open Speed Adjustment

Press P2 again and it will read an alternating "So" and a number. This will adjust the opening speed of the door. The number on the screen represents the frequency of the motor.

#### Closing Speed Adjustment

Press P2 again and it will read an alternating "Sc" and a number. This will adjust the closing speed of the door. The number on the screen represents the frequency of the motor.

#### Close Position

Press P2 again and it will read an alternating "CL" and a number. The number is the distance (more or less) in encoder steps from the closed position to the home position (photo eye). To make the door close less make the number smaller by pushing P3 (each push will change the value by 1) to make it close more make the number larger by pushing P1. Be careful adjusting this number. Start with one or two steps and do more if necessary.

#### Open Position

Once the close limit is set press P2 and the display will change to alternating "OP" and a number. The number is the distance from the open position to the home position with the first digit removed (289 just shows 89). This is changed the same way the closed limit is changed. Be careful adjusting this number. Start with one or two steps and do more if necessary.

When complete release the stop button and the door is back in service. Operate the door to check the limits.

#### Time delay adjustment

Open the door and push in the stop button and then hold the P2 programming button. The display will alternate TO (time open) and an number which is the amount of time delay. Change the number by using P1 to make it larger or P3 to make it smaller. When complete release the stop button and cycle the door twice, it takes two cycles of the door to recognize the new time delay.

## 20. MANUAL OPERATION

- Turn the power off to the door. Serious injury could occur if the door operates while the crank is in the motor.
- Insert the crank provided with the door into the bottom of the motor and turn the crank. The door will open and close based on the direction of rotation.

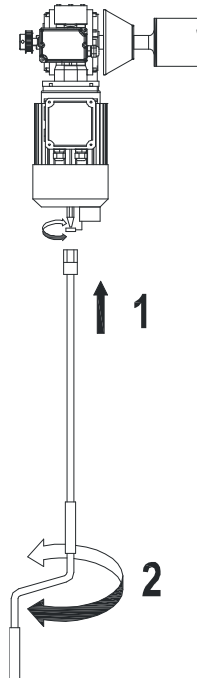

## 21. MISCELLANEOUS OPERATING INSTRUCTIONS

### A. Battery Backup

- Expectations of operation
  - When the main incoming power is lost to the door, the door will lose power and reboot using the batteries.
  - In under a minute the door will open the full height and stay open until power is restored. THIS WILL NOT HAPPEN IF THE POWER IS TURNED OFF AT THE SWITCH ON THE CONTROL PANEL
  - Once the incoming power has been restored, the door will stay open for another minute or 2 and then come completely closed.
  - After the door is completely closed, the operation will be back to normal and the door can be activated using any of the normal activation devices.
- IMPORTANT NOTE: When the install is complete and the door is in normal operation, it is important to let the batteries fully charge before turning local power off to the control panel. This process takes 24-48 hours.

### B. Power Failure with no Battery Backup

- If power is lost to the door and there is no battery backup option on the door, the only options of egress.
  - Manual Operation
    - With the door, there is a crank that has a 13mm socket attached to the end. This should be kept near the door, if there is no other means of egress.
    - In case of a power loss and no other exit doors, this should be inserted onto the bottom of the motor as show on [PAGE 24](#).

### C. Using Automatic Rethreading Feature

- As shown on [PAGE 18](#) the “Rethread Slot” located at the top of the door, roughly even with the clear opening height.
- When the door is knocked out of the tracks below the clear opening, activate the door, and the zipper will go into the slot and rethread.
- In case of the door getting knocked out above the clear opening, see [PAGE 13](#).

### D. Motor Brake Air Gap Adjustment

1. Depress Emergency Stop push button on front of Control panel
2. Remove 4 Phillips screws from cover on bottom of motor.
3. Check air gap arrow #3 with gauge #4. Gap should be .008-.020” or .2-.6mm
4. Unbend locking tab on lock washer.#1
5. Turn locknut #2 counter clockwise to increase the gap, clockwise to decrease the gap.
6. Find a tab on lock washer that aligns with notch in locknut and bend that tab to engage.
7. Reinstall motor cover, release Emergency Stop button, cycle door to open position and make sure the door doesn't drift shut.

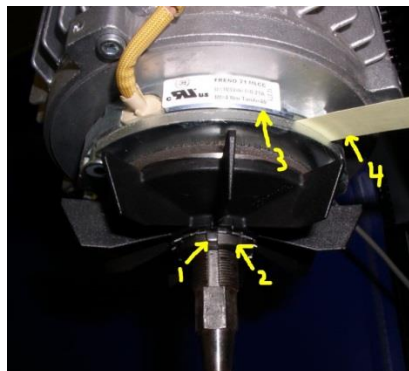

## 22. PERIODIC CHECKS AND MAINTENANCE

### A. Ordinary cleaning and inspection

Ordinary maintenance operations keep the door safe, running well and give it a long life. These items can be done by your maintenance staff and will reduce your overall maintenance costs.

COMPONENT	DESCRIPTION	FREQUENCY
Side Frames	Check that they are securely fastened to the wall and that they are in good condition. They can be cleaned with a soft cloth using soap and water, do not use any solvent. If there is ice on the side frames it should be removed immediately.	6 Months
Photocell and motion detector	They can be cleaned with a soft cloth, do not use any solvent. If the operating area is dusty it may be necessary to clean the photocells more frequently as dust could cause them to not function properly.	6 Months
Windows	They can be cleaned with a soft cloth using soap and water; do not use any solvent or ammonia based cleaners as that could damage the window.	6 Months
Curtain	Check the condition of the curtain and its attachment and repair or replace as necessary. Clean with soap and water only, do not use solvents.	6 Months

### B. Planned inspections and maintenance

Only people trained to inspect and maintain the Jamison/BMP roll up doors should do the following tasks. The maintenance is required to maintain the factory warranty.

Item	Task	Frequency
Structure	Check that they are securely fastened to the wall and that they are in good condition. Repair or replace any damaged components as necessary.	6 Months
Electrical components	Check the electrical connections in the control panel, especially the plugged connections, to be sure they are tight and verify that there is no water in the panel. Check the electrical connections in the junction boxes and control that there is no water in them. Check the condition and operation of all the safety components (photocells, safety edge and emergency button) to be sure they are operating properly. Serious injury or door damage could occur if they do not work. Replace malfunctioning components. Check the condition and operation of the opening devices (push buttons, pull cords, etc). Check that all the wiring is in good condition, replace damaged wires.	6 Months
Mechanical components	Check the overall condition of the motor and for any signs of overheating. Check the condition of the motor brake (see <a href="#">OPERATING INSTRUCTIONS</a> ). Check the drive chain for wear and tension (about ¼" of slack and add moly chain lube). Check the reducer for leaks; be sure it is securely attached to the motor and that the rest of the drive support structure is attached securely. Check all of the bolts to be sure they are tight and not coming loose. Check the alignment of the roll. Check the condition of the bearings and grease as required (NLGI 2 grease). Check the conditions of the curtain guides and the anti-wear washers. Repair or replace any damaged components that are found.	6 Months
Curtain	Check for wear especially in areas where it contacts other components. Check for tears and repair. Check that the curtain is rolling without wrinkles and is straight. Check and adjust the curtain tension as needed and check the condition of the zipper along the side of the curtain. Repair or replace any damaged components that are found.	6 Months

## 23. TROUBLE SHOOTING

It's best to check the LED indicator first before addressing error codes on the display. First correct problems to get the LED indicators correct and then start working on the error codes.

The control board LED indicators do not light	<p>Check the incoming power to be sure it is on and is the correct voltage for the door.</p> <p>Check the fuses and/or circuit breakers.</p>
The door will not jog using P1 or P3	<p>Be sure the Stop button on the front of the panel is not pushed in (LED 6 on).</p> <p>Check the motor wiring to be sure it is correct for the supply voltage. 230VAC is a Y connection, 460VAC is a Delta connection.</p> <p>Check the motor setting (KW) on the control board (can only be done if you have a programming device)</p>
The door will not go through its initial programming of the limits.	<p>Be sure the Stop button on the front of the panel is not pushed in (LED 6 on).</p> <p>Jog the door using P1 and P3 about 18 inches. This will help the door recognize the encoder.</p> <p>Check that LED 13 is on when the door is open. If not then the reversing edge is not recognized. Check the programming and installation of the edge. To check it you can put a jumper from 7-13 temporarily to help diagnose the problem. <b>DO NOT PUT THE DOOR INTO OPERATION WITH THIS JUMPER IN PLACE.</b></p> <p>Switch the encoder signal wires on terminals 17 and 18 (yellow and green).</p>
The reversing edge does not program properly	<p>Check that the jumper J1 in the transmitter is removed.</p> <p>Reset the codes by closing the jumper MR and pressing the PROG button until you hear a short series of beeps, release the PROG button and then remove the jumper.</p> <p>Check the condition of the batteries in the transmitter and replace if they are bad.</p> <p>Check the resistance (8.2 KΩ) of the edge wire. If the edge is pneumatic, check the condition of the tube and the switch.</p> <p>Press the edge and if it does not change then replace it.</p> <p>Be sure the edge wire is not twisted in the bottom of the door.</p> <p>Check the wiring connections for the receiver and verify it is wired correctly.</p>
The door will not close, LD7 is off	<p>Check that the photo cells are installed properly and are aligned.</p> <p>Check the wiring to the photo cells to be sure the brown wire is +12VDC and the blue wire is DC neutral. If they are wired backwards the sensor could be damaged.</p>
LD1 remains on after power up	<p>Check the fuse/circuit breaker</p> <p>The control card has failed, replace the control card.</p>
The door does not close automatically.	<p>Check that DIP switch 1 is set to ON</p> <p>Check the safety inputs to be sure they are not active. LD7, LD13 and LD6 should be on</p>
The door generally works fine but will randomly stop.	<p>Make sure the wires for the brake and light are not in the same conduit/cable as the photocell.</p> <p>Check that the supply voltage is within limits, if not then correct the supply voltage.</p> <p>If you have a programming device</p> <ul style="list-style-type: none"> <li>• Check the bus voltage to be sure it is not lower than 300V, call the factory.</li> <li>• Check that the motor current draw is not more than 9A. If it is lower then decrease the opening speed.</li> </ul>
The photo eye does not reverse the door but the door operates.	<p>Be sure there are no other photo eyes in the area that may interfere with this door's operation</p> <p>Check that the photo eye wiring is not in the same conduit/bundle with any of the high voltage wiring (motor, brake, light)</p> <p>Ground the negative side of the receiver, this is the blue wire in the black cable.</p>
The door drifts closed after stopping in the open position	<p>Tighten the motor brake by removing the motor fan cover and tightening the brake no more than ¼ turn. Check to see if this solves the problem, if not tighten some more and recheck.</p>

## 24. ERROR CODES

Error Code	Description	Solution
00	Undetermined error	Check LEDs and correct to normal configuration. See LED function section.
1	Internal failure	Replace controller
2	Internal failure	Replace controller
4	Internal failure	Replace controller
5	Internal failure	Replace controller
11	Short circuit on the accessories (lamp or brake).	Disconnect both the lamp and brake and then reconnect one at a time to identify the problem. Once identified correct the short circuit.
12	Motor short circuit	This is a short circuit in the motor circuit on the controller, replace controller. Primary of transformer could be set incorrectly
30	Internal failure	Replace controller
31	System overload	Speed set is too high, lower opening speed
32	Same as 31	
50	Open brake circuit	Brake circuit is open, check wiring and the status of the manual disconnect switch
51	Brake short circuit	Check wiring to brake or possibly damaged brake
74	Photocell not responding, reversing edge activated, or unroll sensor activated. (Device wired into T7)	Check that the wiring is correct for the photocells and that they are not blocked. Be sure that one is installed on the front of the panel and one is on the back. If the reversing edge has been activated then the alarm will clear after the next successful closing. If the alarm does not disappear, rotate sensitivity adjustment on unroll sensor counterclockwise.
76	Low voltage	Voltage to the controller is too low to operate, check the incoming voltage
79	Input on terminal #9 missing. Wireless edge fault.	Check both double A batteries in transmitter first
7A	Low voltage in UPS system	UPS system low voltage. Check battery voltage in the UPS and line voltage supply to the system.
87	Overvoltage on close	Too much power is being absorbed by the controller, the system will automatically adjust frequency to solve. Check incoming line for high voltage.
88	Overcurrent on close (motor)	Too much current is being absorbed by the controller from the motor. Make sure the wiring is correct.
89	Overcurrent on close (brake)	Too much current is being absorbed by the controller from the brake side of the motor. Make sure the wiring is correct. Similar to 51 but 89 is more specific to the brake.
8A	Overcurrent on close (UPS)	Too much current is being absorbed by the controller when using battery backup. Make sure the motor wiring is correct.
8D	Overheated controller	Allow to cool and check for mechanical problems
8E	Error in VBUS measurement	Controller is reading the wrong VBUS. Replace controller.
8F	Same as 8E	
90	Bad CPU in controller	Replace controller
91	Same as 90	
100	Improper encoder response	Check the reducer ratio and if correct the encoder is not operating properly, replace the encoder.
102	Encoder wiring or noise	The encoder may be wired incorrectly or there may



		be noise on the encoder or photocell circuit. Check wiring and shielding. Also starting door setup at 0qc.
103	Teach mode started with photocell unblocked	Programming was begun with the door too high, photocell may see signal from adjacent door, photocell may be installed incorrectly on the same side of the door.
104	Teach mode started with top override sensor unblocked	Programming was begun with the door too high. Top override sensor may not be seeing the curtain or the set position is above the sensor.
105	Closed position too close to photocell	The closed position must be at least 4" below the photocell.
108	Photocell never disengaged during programming	During teach mode the photocell was not uncovered. Likely caused by the upper limit being set too low or the photocells being misaligned
109	Open position too close to photocell	The open position must be at least 8" above the photo cell
10D	Ped open set too low	The ped open was set below the photocell
10E	Encoder count missing	Encoder is not giving consistent output or the brake is locked on. Check the wiring connections to the encoder to be sure they are tight, check the brake, check the wiring connections to the motor, or replace the encoder.
10F	Photocell not working	Occurs during alignment after a restart if the photocell is not responding, check the photocell to be sure it is not blocked or misaligned. Watch for Id7 to flicker. Be sure photo eyes aren't being partially blocked or re-engaged by the bottom of the door.
110	Same as 10F	
115	Encoder count wrong	Encoder is only seeing one signal. Check wiring of the encoder.
116	Motor selection is incorrect	Use programmer to change motor parameters.
117	Same as 116	
118	Same as 116	
116	Motor selection is incorrect	Use programmer to change motor parameters.
117	Same as 116	
118	Same as 116	

### A. LED Display Code Key

Display Code	Description
te	Door is in teach mode.
St	Emergency Stop is engaged.
J	Door is in Jog mode.
C	Door is closed.
Cl	Door is closing.
Op	Door is opening.
EA	Learning mode. The door is looking for its limits.
Pe	Ped open cycle or ped open push button broken/stuck.